



Lambda Sensor LSU 4.9



- ▶ **Application: Lambda 0.65 to ∞**
- ▶ **Wide band**
- ▶ **Exhaust gas temperature range (max.) for short time < 1,030°C**

This sensor is designed to measure the oxygen content and Lambda value of exhaust gases in automotive engines (gasoline or Diesel).

The wide band Lambda sensor LSU 4.9 is a planar ZrO₂ dual cell limiting current sensor with integrated heater. Its monotonic output signal in the range of Lambda 0.65 to air makes the LSU 4.9 capable of being used as a universal sensor for Lambda 1 measurement as well as for other Lambda ranges. The connector module contains a trimming resistor, which defines the characteristic of the sensor. The LSU 4.9 operates only in combination with a special LSU-IC, used in most Bosch Motorsport ECUs and Lambda control units like LT4.

The main benefit of the LSU 4.9 is the robust design combined with the high Bosch production quality standard.

Application

Application	Lambda 0.65 to ∞
Fuel compatibility	gasoline/Diesel/E85
Exhaust gas pressure	< 4 bar
Exhaust gas temperature range (operating)	< 930°C
Exhaust gas temperature range (max.) for short time	< 1,030°C

Hexagon temperature	< 600°C
Wire and protective sleeve temperature	< 250°C
Connector temperature	< 140°C
Storage temperature range	-40 to 100°C
Max. vibration (stochastic peak level)	< 1,000 m/s ²

Technical Specifications

Variations

LSU 4.9 with automotive connector

Connector	1 928 404 682
Mating connector	D 261 205 356-01
Pin 1	IP / APE
Pin 2	VM / IPN
Pin 3	Uh- / H-
Pin 4	Uh+ / H
Pin 5	IA / RT
Pin 6	UN / RE

LSU 4.9 with motorsports connector

Connector	AS 6-07-35PN
Mating connector	AS 0-07-35SN
Pin 1	Uh+ / H

LSU 4.9 with automotive connector

Pin 2	Uh- / H-
Pin 3	IP / APE
Pin 4	VM / IPN
Pin 5	UN / RE
Pin 6	IA / RT

Mechanical Data

Weight w/o wire	120 g
Length	84 mm
Thread	M18x1.5
Wrench size	22 mm
Tightening torque	40 to 60 Nm

Electrical Data

Power supply H+ nominal	7.5 V
System supply voltage	10.8 V to 16.5 V
Heater power steady state	7.5 W
Heater control frequency	≥ 100 Hz
Nominal resistance of Nernst cell	300 Ω
Max current load for Nernst cell	250 μA

Characteristic

Signal output	Ip meas / Ua (AWS)
Accuracy at Lambda 0.8	0.80 ± 0.01
Accuracy at Lambda 1	1.016 ± 0.007
Accuracy at Lambda 1.7	1.70 ± 0.05

IP	U _A [V]	Lambda
-1.243	0.192	0.750
-0.927	0.525	0.800
-0.800	0.658	0.822
-0.652	0.814	0.850
-0.405	1.074	0.900
-0.183	1.307	0.950
-0.106	1.388	0.970
-0.040	1.458	0.990
0	1.500	1.003
0.015	1.515	1.010
0.097	1.602	1.050

0.193	1.703	1.100
0.250	1.763	1.132
0.329	1.846	1.179
0.671	2.206	1.429
0.938	2.487	1.701
1.150	2.710	1.990
1.385	2.958	2.434
1.700	3.289	3.413
2.000	3.605	5.391
2.150	3.762	7.506
2.250	3.868	10.119

Connectors and Wires

Connector	Please see variations
Mating connector	Please see variations
Sleeve	fiber glass / silicone coated
Wire size	AWG 24
Wire length L	32.5 cm

Various motorsport and automotive connectors are available on request.
Please specify the required wire length with your order.

Installation Notes

The LSU 4.9 can be connected to most Bosch Motorsport ECUs and lambda control units like LT4.

The lambda sensor should be installed at point which permits the measurement of a representative exhaust-gas mixture, which does not exceed the maximum permissible temperature.

Install at a point where the gas is as hot as possible.

Observe the maximum permissible temperature.

As far as possible install the sensor vertically (wire upwards).

The sensor is not to be fitted near to the exhaust pipe outlet, so that the influence of the outside air can be ruled out.

The exhaust-gas passage opposite the sensor must be free of leaks in order to avoid the effects of leak-air.

Protect the sensor against condensation water.

The sensor is not to be painted, nor is wax to be applied or any other forms of treatment. Use only the recommended grease for lubricating the thread.

Please find further application hints in the offer drawing at our homepage.

Dimensions

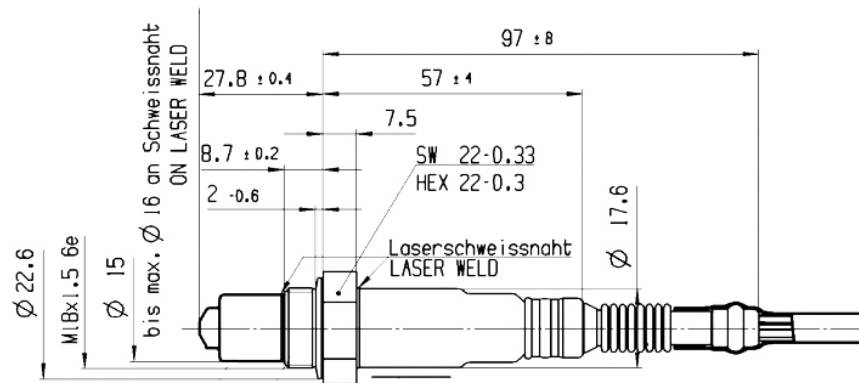

Ordering Information

Lambda Sensor LSU 4.9 **0 258 017 025**

With automotive connector

Lambda Sensor LSU 4.9 **B 261 209 356-05**

With motorsports connector

Europe:

Bosch Engineering GmbH
Motorsport
Robert-Bosch-Allee 1
74232 Abstatt
Germany
Tel.: +49 7062 911 79101
Fax: +49 7062 911 79104
motorsport@bosch.com
www.bosch-motorsport.de

North and South America:

Bosch Engineering North America
Motorsports
38000 Hills Tech Drive
Farmington Hills, MI 48331-3417
United States of America
Tel.: +1 248 876 2977
Fax: +1 248 876 7373
motorsport@bosch.com
www.bosch-motorsport.com

Asia Pacific:

Bosch Engineering Japan K.K.
Motor Sport Department
3-33-8 Tsuruya-cho, Kanagawa-ku, Yokohama-shi
Kanagawa 221-0835
Japan
Tel.: +81 45 410 1650
Fax: +81 45 410 1651

Represented by